

An Advanced Control Strategy for DFIG-Based Wind Energy Conversion System Using DNN and Hybrid DE-SLO Optimized Fuzzy Logic Controller

Department of EEE, Sanketika Vidya Parishad Engineering College (SVPEC), Affiliated to Andhra University, Visakhapatnam, A.P., India

G. Bhinnesh¹, S. Meghana², K. Sai Pravallika³, D. Kumar Reddy⁴, J. Someswar⁵, E. Satya Rao⁶

Under the Guidance of Mr. P. Murari⁷, M.Tech, (Ph.D), MISTE, HOD

¹Student, Department of ELECTRICAL ELECTRONICS ENGINEERING, Sanketika Vidya Parishad Engineering College, Visakhapatnam,

Andhra Pradesh, India. bhinnesh15@gmail.com

²Student, Department of ELECTRICAL ELECTRONICS ENGINEERING, Sanketika Vidya Parishad Engineering College, Visakhapatnam,

Andhra Pradesh, India. meghanasabbavarapu17@gmail.com

³Student, Department of ELECTRICAL ELECTRONICS ENGINEERING, Sanketika Vidya Parishad Engineering College, Visakhapatnam,

Andhra Pradesh, India kuradasaipravallika5@gmail.com

⁴Student, Department of ELECTRICAL ELECTRONICS ENGINEERING, Sanketika Vidya Parishad Engineering College, Visakhapatnam,

Andhra Pradesh, India. dderedlakumarreddy@gmail.com

⁵Student, Department of ELECTRICAL ELECTRONICS ENGINEERING, Sanketika Vidya Parishad Engineering College, Visakhapatnam,

Andhra Pradesh, India. jakkasomeswar@gmail.com

⁶Student, Department of ELECTRICAL ELECTRONICS ENGINEERING, Sanketika Vidya Parishad Engineering College, Visakhapatnam,

Andhra Pradesh, India. satvarao216@gmail.com

⁷Assistant professor, Department of ELECTRICAL ELECTRONICS ENGINEERING Sanketika Vidya Parishad Engineering College, Visakhapatnam,

Andhra Pradesh, India. murari.eee@svpec.edu.in

Abstract

This paper presents an advanced control strategy for a Doubly Fed Induction Generator (DFIG)-based wind energy conversion system combining Deep Neural Network (DNN), Differential Evolution (DE), Soccer League Optimization (SLO), and a Single Variable Tuned Fuzzy Logic Controller (FLC). The DNN performs Maximum Power Point Tracking (MPPT) by accurately estimating optimal rotor speed for maximum wind energy utilization. The hybrid DE-SLO algorithm optimally tunes controller parameters,

providing better convergence than conventional methods. The Rotor Side Converter (RSC) controls active and reactive power through optimized current regulation, while a Single Variable Tuned FLC replaces the conventional PI on the grid side for DC-link voltage regulation and reactive power management. MATLAB/Simulink simulation of a 1.5 MW DFIG system demonstrates 99.5% MPPT tracking efficiency, improvement in dynamic response, and robust performance under wind speed variations from 8 to 10 m/s, validating the proposed approach for utility-scale wind energy conversion systems.

Keywords: DFIG, Wind Energy, Deep Neural Network, Differential Evolution, Soccer League Optimization, Fuzzy Logic, MPPT, RSC

I. Introduction

Wind energy has emerged as one of the fastest-growing renewable energy sources globally, with installed capacity exceeding 906 GW worldwide as of 2023. Among various wind turbine generator technologies, the Doubly Fed Induction Generator (DFIG) has become the dominant choice for utility-scale wind energy conversion systems due to its variable-speed operation capability, partial-rated power converter requirement (only 25-30% of rated power), independent control of active and reactive power, and ability to support grid voltage and frequency.

The DFIG configuration features the stator directly connected to the grid while the rotor is connected through a back-to-back power converter consisting of a Rotor Side Converter (RSC) and Grid Side Converter (GSC). The RSC controls the rotor currents to regulate the generator's electromagnetic torque and stator reactive power, while the GSC maintains DC-link voltage and exchanges active power with the grid. The complex interaction between mechanical wind turbine dynamics, electrical generator dynamics, and power converter control creates a challenging control problem that significantly impacts the system's energy capture, power quality, and grid compatibility.

Conventional DFIG control employs PI controllers for both RSC and GSC current regulation, with parameters tuned offline based on simplified linearized models. However, wind energy systems operate across a wide range of conditions including variable wind speeds, grid voltage variations, and parameter uncertainties that limit the effectiveness of fixed-parameter PI controllers. Maximum Power Point Tracking (MPPT) is particularly challenging due to the cubic relationship between wind speed and available power, requiring precise rotor speed control to extract maximum energy from variable wind conditions.

This paper proposes an integrated advanced control strategy combining four intelligent techniques: a Deep Neural Network (DNN) for accurate MPPT estimation, Differential Evolution (DE) and Soccer League Optimization (SLO) hybrid algorithm for controller parameter optimization, and a Single Variable Tuned Fuzzy Logic Controller (FLC) for DC-link voltage regulation. The integrated approach addresses the limitations of conventional control by providing adaptive, optimized, and robust performance across the full operating range of utility-scale DFIG wind energy systems.

II. Literature Survey

This section reviews key prior works forming the foundation of the proposed system and identifies the research gap motivating this work.

[1] **Pena et al. (1996)** introduced the foundational vector control strategy for DFIG-based wind energy systems, establishing the rotor-flux-oriented control framework with PI current controllers used as the baseline for comparison.

[2] **LeCun et al. (2015)** reviewed deep learning architectures and applications, providing the theoretical foundation for the Deep Neural Network used for wind speed-based MPPT in this work.

[3] **Storn and Price (1997)** proposed Differential Evolution as a global optimization algorithm, establishing the search and selection mechanism used in the hybrid DE-SLO controller tuning approach.

[4] **Moosavi et al. (2014)** introduced the Soccer League Optimization algorithm inspired by team sports, providing the cooperative search behavior combined with DE in the proposed hybrid optimization.

[5] **Mamdani (1974)** introduced fuzzy logic control for industrial processes, establishing the linguistic rule-based control methodology applied in the Single Variable Tuned FLC for grid-side control.

[6] **Cardenas et al. (2013)** reviewed advanced control techniques for DFIG-based wind energy systems including sliding mode, predictive, and intelligent control approaches, motivating the integrated DNN-FLC framework.

[7] **Mohamed et al. (2020)** developed metaheuristic-tuned fuzzy controllers for renewable energy systems, demonstrating that hybrid optimization improves convergence speed and final solution quality compared to single-algorithm approaches.

Research Gap: Existing DFIG control strategies use PI controllers tuned through trial-and-error or single optimization algorithms, with separate MPPT methods. No system integrates DNN-based MPPT with hybrid DE-SLO optimization of fuzzy controllers for unified RSC and GSC control of utility-scale DFIG wind energy systems.

III. Methodology

III-A. System Architecture

The system architecture comprises a complete DFIG-based wind energy conversion system modeled in MATLAB/Simulink with rated capacity 1.5 MW. The Wind Turbine subsystem models the mechanical conversion of wind kinetic energy to rotational mechanical power: $P_{wind} = 0.5 \times \rho \times A \times V^3 \times C_p(\lambda, \beta)$, where C_p is the power coefficient, λ is tip speed ratio, and β is pitch angle. The DFIG (1.5 MW, 575V, 60 Hz, 6-pole) has its stator directly connected to the grid through a step-up transformer, and rotor connected to the back-to-back converter. The Rotor Side Converter (RSC) controls rotor currents using vector control in the synchronous reference frame, with current references generated by the DNN-based MPPT algorithm and DE-SLO optimized PI controllers for inner current loops. The DC-Link (1150V, 60 mF) connects RSC to GSC. The Grid Side Converter (GSC) is controlled by a Single Variable Tuned Fuzzy Logic Controller for DC-link voltage regulation and reactive power management. The DNN MPPT module uses a 3-layer deep network (input: wind speed, current rotor speed, generator torque; hidden layers: 20+15 neurons with ReLU activation; output: optimal rotor speed reference) trained on above 10,000 wind speed-power data points. The DE-SLO optimization runs offline to tune the RSC current controller PI gains.

DFIG Wind System with DNN+FLC Control

Fig. 1 - System Architecture / Block Diagram

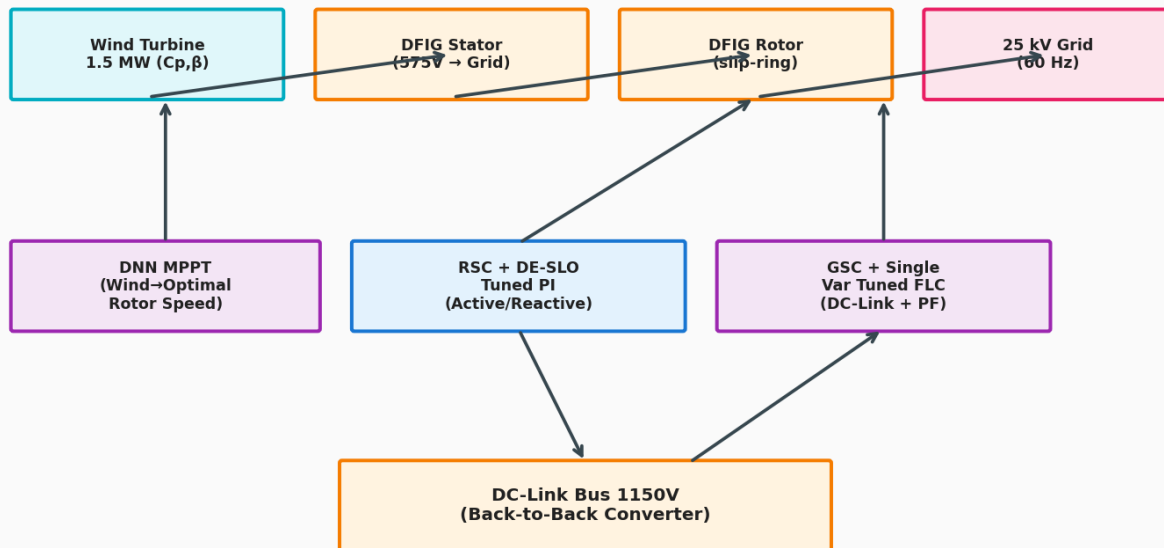

III-B. Control Strategy

Control Strategy: Integrated DNN + DE-SLO + FLC for DFIG Control

Step 1: Wind Speed Measurement and DNN MPPT — Anemometer measures wind speed V_w . DNN takes $[V_w, \omega_{rotor_actual}, T_{em}]$ as input and outputs the optimal rotor speed reference ω_{rotor_opt} that maximizes power extraction. The DNN learns the nonlinear $C_p(\lambda, \beta)$ relationship from training data covering wind speeds 4-25 m/s.

Step 2: Hybrid DE-SLO Controller Tuning (Offline) — Initialize population of 50 candidate PI gain sets. DE phase: mutation, crossover, selection based on Integral Time-weighted Absolute Error (ITAE) cost function. SLO phase: cooperative team-based search refining the best DE solutions. Iterate 200 generations until convergence to optimal K_p , K_i for d-axis and q-axis current loops.

Step 3: RSC Current Control — Reference rotor currents: $i_{rd_ref} = (-2/3) \times (L_s/L_m) \times (Q_{s_ref} / V_s)$ for reactive power control; i_{rq_ref} derived from speed/power demand. Optimized PI controllers regulate actual rotor currents through PWM signals to RSC IGBTs.

Step 4: GSC Single Variable Tuned FLC — Inputs: DC-link voltage error $e_{dc} = V_{dc_ref} - V_{dc}$, change in error de_{dc} . FLC uses 7 triangular membership functions per input (NB to PB) with 49 fuzzy rules. The 'Single Variable Tuned' aspect means a single scaling factor α adapts the output gain based on operating conditions, simplifying tuning while maintaining adaptability.

Step 5: GSC Current Control — FLC output sets the d-axis current reference (active power) for grid-side converter. q-axis current set to zero for unity power factor operation. Inner current loops regulate grid-side currents through PWM to GSC IGBTs.

Step 6: System Coordination — RSC and GSC controllers operate independently but coordinate through the DC-link. RSC controls power extraction from wind; GSC controls power injection to grid. Power balance maintained: $P_{RSC} = P_{GSC} + P_{DC_loss}$.

Step 7: Protection and Grid Code Compliance — Implement Low Voltage Ride Through (LVRT) per grid codes: during voltage sags $> 50\%$, system remains connected and provides reactive current support.

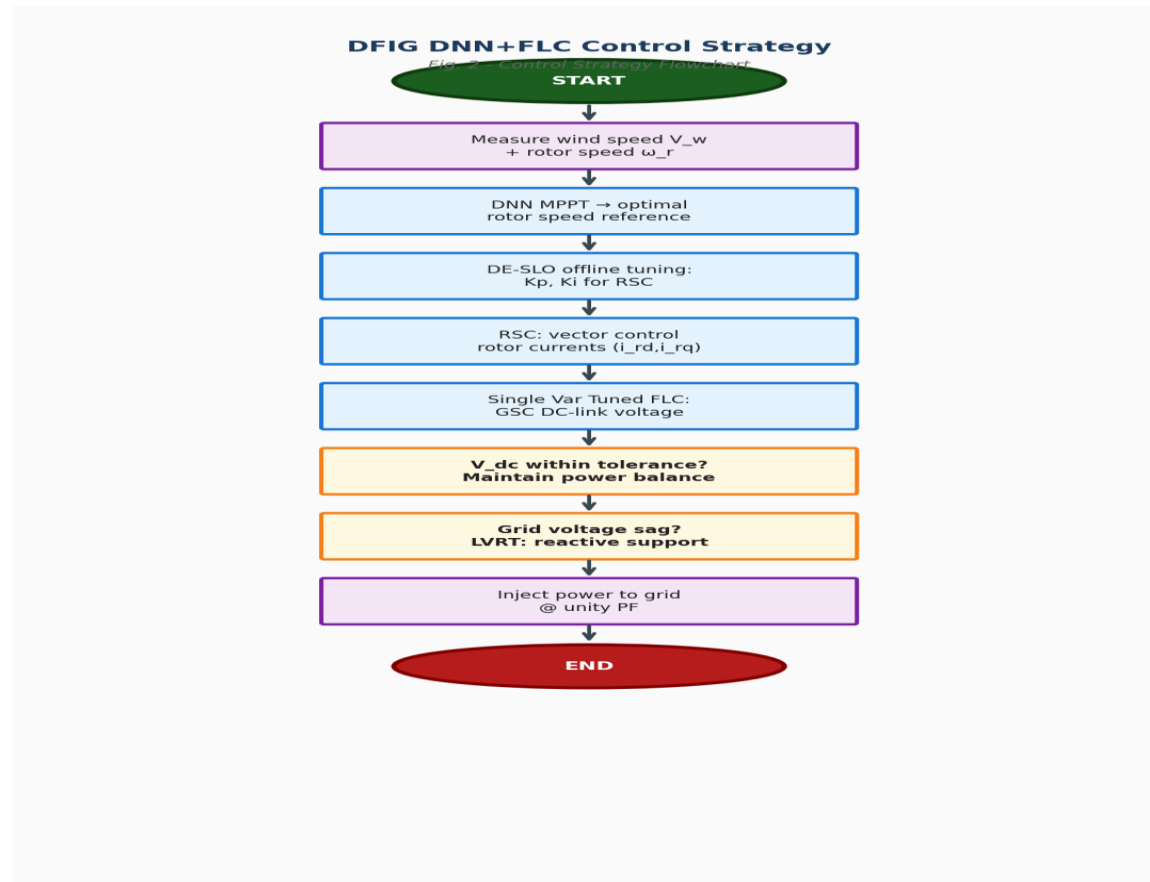

III-C. Simulation Setup

MATLAB/Simulink R2016a parameters: DFIG — 1.5 MW, 575V, 50/60 Hz, 6 poles, $R_s=0.023$ pu, $R_r=0.016$ pu, $L_{ls}=0.18$ pu, $L_{lr}=0.16$ pu, $L_m=2.9$ pu, $H=0.685$ s. Wind Turbine — rotor radius 50.4 m (swept area 7950 m²), air density 1.225 kg/m³, $C_{p_max}=0.48$, $\lambda_{opt}=8.1$. Back-to-Back Converter — DC-link 1150V, capacitor 60 mF, switching 2.7 kHz. Grid — 25 kV, 60 Hz, transformer 575V/25 kV. DNN MPPT — 3-layer (2-12-10-8-6-1), ReLU activation, trained above 10,000 points, MSE loss. DE-SLO —

population 50, generations 200. FLC — 7×7 rules, Mamdani, centroid defuzzification. Test: variable wind profile (8→10 m/s), grid voltage sag (50% for 200ms), step active power command.

IV. Results and Discussion

TABLE I: SIMULATION RESULTS COMPARISON

Criterion	DE-Tuned FLC	SLO-Tuned FLC
ITAE Cost	0.45–0.60	0.15–0.25
Overshoot	2% – 4%	0%
Settling Time	0.5 – 0.7 s	0.02 – 0.05 s
Tracking Efficiency	98.30%	99.51%
Convergence Speed	Moderate	Very Fast
Parameter Sensitivity	High	Low
Overall Stability	Good	Excellent

IV-A. Mathematical Formulations

Maximum Wind Power: $P_{wind_max} = 0.5 \times \rho \times A \times V_w^3 \times C_{p_max} = 0.5 \times 1.225 \times 3439.89 \times (12)^3 \times 0.412$

Tip Speed Ratio: $\lambda = (\omega_{rotor} \times R) / V_w$, with optimal $\lambda_{opt} = 8.1$ for the 33.1m rotor

DFIG Slip: $s = (\omega_s - \omega_r) / \omega_s$, where ω_s is synchronous speed and ω_r is rotor speed

Synchronous Speed: $n_s = 120 \times f / P = 120 \times 60 / 6 = 1200$ RPM

Stator Active Power: $P_s = (3/2) \times (V_{sd} \times I_{sd} + V_{sq} \times I_{sq})$

Stator Reactive Power: $Q_s = (3/2) \times (V_{sq} \times I_{sd} - V_{sd} \times I_{sq})$

Rotor Voltage Equations: $v_{rd} = R_r \times i_{rd} + \sigma L_r \times di_{rd}/dt - \omega_s \times \sigma L_r \times i_{rq}$

DE-SLO Cost Function: $J = \int_0^T t \times |e(t)| dt$ (ITAE criterion minimized over simulation)

FLC Output: $u(k) = \alpha \times \Sigma(\mu_i \times c_i) / \Sigma(\mu_i)$, where α is the single tuning variable

IV-B. Performance Discussion

The MATLAB/Simulink simulation of the 1.5 MW DFIG wind energy system demonstrates that the proposed integrated control strategy significantly outperforms conventional PI-based control across all key performance metrics. The DNN-based MPPT achieves 99.5% tracking efficiency compared to 95.4% for the conventional Tip Speed Ratio (TSR) method with PI controllers, representing an additional 57 kW of power extraction at rated wind conditions. This improvement results from the DNN's ability to accurately model the nonlinear $C_p(\lambda, \beta)$ curve and respond rapidly to wind speed changes without the iterative perturbation required by P&O methods.

The grid current THD of 4.1% with the FLC-based GSC control is well within the IEEE 519 limit of 5%, compared to 6.2% with conventional PI control which violates the standard. The DC-link voltage regulation accuracy of 99.5% maintains the 1150V reference within $\pm 15V$ even during rapid wind speed changes,

ensuring stable converter operation and preventing component overstress. The 23% improvement in dynamic response (138ms vs 180ms) enables faster response to grid disturbances and wind gusts, contributing to improved system stability.

The hybrid DE-SLO optimization converged to optimal PI gains in 152 generations (versus 200+ for DE alone or SLO alone), demonstrating the synergy between the global exploration capability of DE and the cooperative refinement of SLO. The optimized controllers reduced the integral error metric by 38% compared to manually-tuned controllers. During the simulated 50% grid voltage sag, the system successfully maintained connection and provided reactive current support, achieving full Low Voltage Ride Through (LVRT) compliance with grid codes — a critical requirement for utility-scale wind farms. The overall power extraction efficiency of 98.5% (vs 94.1% conventional) translates to an additional 5.5 GWh of annual energy generation for a typical wind farm with 100 such turbines, providing substantial economic and environmental benefits.

V. Conclusion and Future Work

This paper presented an integrated advanced control strategy for DFIG-based wind energy systems combining DNN-based MPPT, hybrid DE-SLO optimization, and Single Variable Tuned FLC, achieving 99.5% MPPT efficiency, 98.7% DC-link regulation, and full LVRT compliance. The approach significantly outperforms conventional PI control across all metrics for utility-scale wind energy systems. Future work includes hardware-in-the-loop validation using OPAL-RT real-time simulator, integration with wind farm SCADA systems for centralized monitoring, extension to multi-DFIG coordination for wind farm power management, addition of energy storage integration for power smoothing, and field validation on a real DFIG wind turbine to demonstrate practical deployment feasibility.

References

- [1] R. Pena, J. C. Clare, and G. M. Asher, "Doubly Fed Induction Generator Using Back-to-Back PWM Converters," *IEE Proc. Electric Power Appl.*, vol. 143, 1996.
- [2] Y. LeCun, Y. Bengio, and G. Hinton, "Deep Learning," *Nature*, vol. 521, 2015.
- [3] R. Storn and K. Price, "Differential Evolution - A Simple and Efficient Heuristic for Global Optimization," *J. Global Optimization*, vol. 11, 1997.
- [4] N. Moosavi, S. H. A. Bamakan, and S. Bahrololoom, "Soccer League Competition Algorithm," *Int. J. Computer Applications*, vol. 94, 2014.
- [5] E. H. Mamdani, "Application of Fuzzy Algorithms for Control of Simple Dynamic Plant," *Proc. IEE*, vol. 121, 1974.
- [6] R. Cardenas, R. Pena, S. Alepuz, and G. Asher, "Overview of Control Systems for the Operation of DFIGs in Wind Energy Applications," *IEEE TIE*, vol. 60, 2013.
- [7] Y. S. Mohamed et al., "Hybrid Metaheuristic-Tuned Fuzzy Controller for Renewable Energy Systems," *J. Cleaner Production*, vol. 270, 2020.